



EXCEL ENGINEERING COLLEGE (AUTONOMOUS)

Approved by AICTE, New Delhi & Affiliated to Anna University, Chennai

Accredited by NBA (AERO, CSE, ECE, MECH), NAAC with "A" and Recognised by UGC (2f & 12B)

KOMARAPALAYAM - 637303

DEPARTMENT OF MECHANICAL ENGINEERING

GATE EXAM

ACADEMIC YEAR (2022-2023)

S.No.	YEAR	Name of the Activity	Number of Students attended / Participated	Remarks
1	2022 -2023	Competitive coaching and motivational program for Higher education	40	
2	2022 -2023	Being an Engineer - Career Guidance Program	60	

Staff Incharge

HOD/MECH

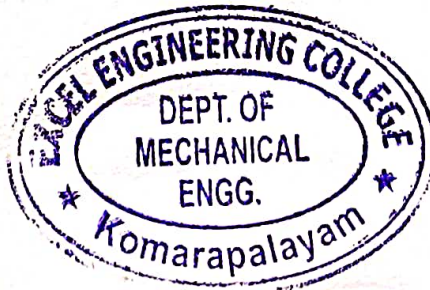
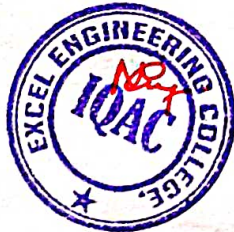

HEAD OF THE DEPARTMENT
MECHANICAL ENGINEERING
EXCEL ENGINEERING COLLEGE
KOMARAPALAYAM - 637303



EXCEL ENGINEERING COLLEGE
(Autonomous)

Approved by AICTE, New Delhi & Affiliated to Anna University, Chennai
Accredited by NBA(AERO,CSE,ECE,MECH) , NAAC with "A" and Recognised by UGC (2f &12B)
KOMARAPALAYAM - 637303

DEPARTMENT OF MECHANICAL ENGINEERING

CIRCULAR

Date: 07.10.2022

It is informed that there will be a "GATE Coaching Class" starts from 10.10.2022 onwards at 4.30 PM to 6.00 PM in Paavaiammal Hall for our department students. So I request the faculty members to permit the students to attend without fail.

N. Nataraj
HOD/MECH

TO

1. Department Notice Board

Copy to,

1. Circulated to all faculty members
2. Principal
3. File

**HEAD OF THE DEPARTMENT
MECHANICAL ENGINEERING,
EXCEL ENGINEERING COLLEGE
KOMARAPALAYAM - 637303**

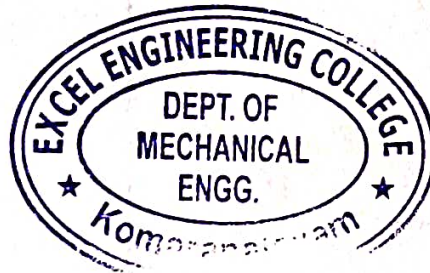



EXCEL ENGINEERING COLLEGE (Autonomous)

Approved by AICTE, New Delhi & Affiliated to Anna University, Chennai
Accredited by NBA (AERO, CSE, ECE & MECH), NAAC with "A" and Recognised by UGC (2f & 12B)
KOMARAPALAYAM - 637303

DEPARTMENT OF MECHANICAL ENGINEERING

GATE COACHING CLASS SCHEDULE (10.10.2022 to 14.10.2022)

S.NO	DAY	TOPIC	FACULTY NAME	DEPT	TIME	REMARKS
1	Monday (10.10.2022)	Heat Transfer	Dr.N.Tamilselvan	MECH	4.30 PM to 6.00 PM	
2	Tuesday (11.10.2022)	Thermodynamics	Dr.R.Vinoth	MECH	4.30 PM to 6.00 PM	
3	Wednesday (12.10.2022)	Fluid Mechanics	Dr.N.Venkadachalam	MECH	4.30 PM to 6.00 PM	
4	Thursday (13.10.2022)	Machine Design	Mr.V.Karthikeyan	MECH	4.30 PM to 6.00 PM	
5	Friday (14.10.2022)	Engineering Mechanics	Mr.T.M.Sakthimuruga	MECH	4.30 PM to 6.00 PM	

STAFF COORDINATOR

HOD/MECH

HEAD OF THE DEPARTMENT
MECHANICAL ENGINEERING,
EXCEL ENGINEERING COLLEGE
KOMARAPALAYAM - 637303.

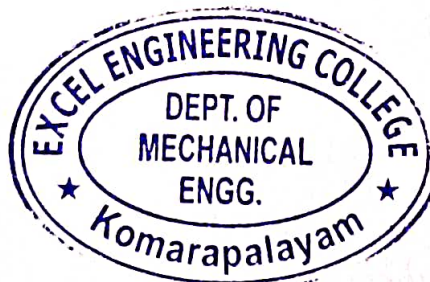

GATE

SYLLABUS

Section 1: Engineering Mathematics

Linear Algebra: Matrix algebra, systems of linear equations, eigenvalues and eigenvectors.

Calculus: Functions of single variable, limit, continuity and differentiability, mean value theorems, indeterminate forms; evaluation of definite and improper integrals; double and triple integrals; partial derivatives, total derivative, Taylor series (in one and two variables), maxima and minima, Fourier series; gradient, divergence and curl, vector identities, directional derivatives, line, surface and volume integrals, applications of Gauss, Stokes and Green's theorems.

Differential equations: First order equations (linear and nonlinear); higher order linear differential equations with constant coefficients; Euler-Cauchy equation; initial and boundary value problems; Laplace transforms; solutions of heat, wave and Laplace's equations.

Complex variables: Analytic functions; Cauchy-Riemann equations; Cauchy's integral theorem and integral formula; Taylor and Laurent series.

Probability and Statistics: Definitions of probability, sampling theorems, conditional probability; mean, median, mode and standard deviation; random variables, binomial, Poisson and normal distributions.

Numerical Methods: Numerical solutions of linear and non-linear algebraic equations; integration by trapezoidal and Simpson's rules; single and multi-step methods for differential equations.

Section 2: Applied Mechanics and Design

Engineering Mechanics: Free-body diagrams and equilibrium; trusses and frames; virtual work; kinematics and dynamics of particles and of rigid bodies in plane motion; impulse and momentum (linear and angular) and energy formulations, collisions.

Mechanics of Materials: Stress and strain, elastic constants, Poisson's ratio; Mohr's circle for plane stress and plane strain; thin cylinders; shear force and bending moment diagrams; bending and shear stresses; deflection of beams; torsion of circular shafts; Euler's theory of columns; energy methods; thermal stresses; strain gauges and rosettes; testing of materials with universal testing machine; testing of hardness and impact strength.

Theory of Machines: Displacement, velocity and acceleration analysis of plane mechanisms; dynamic analysis of linkages; cams; gears and gear trains; flywheels and governors; balancing of reciprocating and rotating masses; gyroscope.

Vibrations: Free and forced vibration of single degree of freedom systems, effect of damping; vibration isolation; resonance; critical speeds of shafts.

Machine Design: Design for static and dynamic loading; failure theories; fatigue strength and the S-N diagram; principles of the design of machine elements such as bolted, riveted and welded joints; shafts, gears, rolling and sliding contact bearings, brakes and clutches, springs.

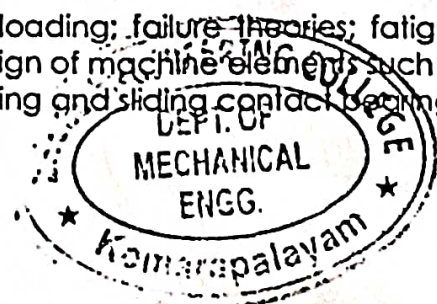

Section 3: Fluid Mechanics and Thermal Sciences

Fluid Mechanics: Fluid properties; fluid statics, manometry, buoyancy, forces on submerged bodies, stability of floating bodies; control-volume analysis of mass, momentum and energy; fluid acceleration; differential equations of continuity and momentum; Bernoulli's equation; dimensional analysis; viscous flow of incompressible fluids, boundary layer, elementary turbulent flow, flow through pipes, head losses in pipes, bends and fittings.

Heat-Transfer: Modes of heat transfer; one dimensional heat conduction, resistance concept and electrical analogy, heat transfer through fins; unsteady heat conduction, lumped parameter system, Heisler's charts; thermal boundary layer, dimensionless parameters in free and forced convective heat transfer, heat transfer correlations for flow over flat plates and through pipes, effect of turbulence; heat exchanger performance, LMTD and NTU methods; radiative heat transfer, Stefan-Boltzmann law, Wien's displacement law, black and grey surfaces, view factors, radiation network analysis.

Thermodynamics: Thermodynamic systems and processes; properties of pure substances, behaviour of ideal and real gases; zeroth and first laws of thermodynamics, calculation of work and heat in various processes; second law of thermodynamics; thermodynamic property charts and tables, availability and irreversibility; thermodynamic relations.

Applications: *Power Engineering:* Air and gas compressors; vapour and gas power cycles, concepts of regeneration and reheat. *I.C. Engines:* Air-standard Otto, Diesel and dual cycles. *Refrigeration and air-conditioning:* Vapour and gas refrigeration and heat pump cycles; properties of moist air, psychrometric chart, basic psychrometric processes. *Turbomachinery:* Impulse and reaction principles, velocity diagrams, Pelton-wheel, Francis and Kaplan turbines.

Section 4: Materials, Manufacturing and Industrial Engineering

Engineering Materials: Structure and properties of engineering materials, phase diagrams, heat treatment, stress-strain diagrams for engineering materials.

CASTING, FORMING AND JOINING PROCESSES: Different types of castings, design of patterns, moulds and cores; solidification and cooling; riser and gating design. Plastic deformation and yield criteria; fundamentals of hot and cold working processes; load estimation for bulk (forging, rolling, extrusion, drawing) and sheet (shearing, deep drawing, bending) metal forming processes; principles of powder metallurgy. Principles of welding, brazing, soldering and adhesive bonding.

MACHINING AND MACHINE TOOL OPERATIONS: Mechanics of machining; basic machine tools; single and multi-point cutting tools, tool geometry and materials, tool life and wear; economics of machining; principles of non-traditional machining processes; principles of work holding, design of jigs and fixtures.

Metrology and Inspection: Limits, fits and tolerances; linear and angular measurements; comparators; gauge design; interferometry; form and finish measurement; alignment and testing methods; tolerance analysis in manufacturing and assembly.

Computer Integrated Manufacturing: Basic concepts of CAD/CAM and their integration tools.

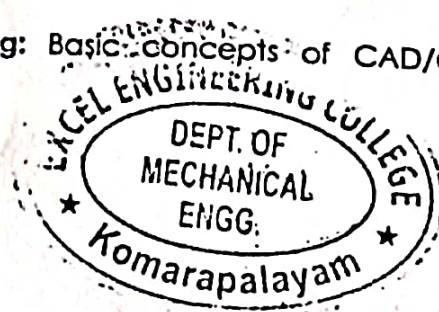

Production Planning and Control: Forecasting models, aggregate production planning, scheduling, materials requirement planning.

Inventory Control: Deterministic models; safety stock inventory control systems.

Operations Research: Linear programming, simplex method, transportation, assignment, network flow models, simple queuing models, PERT and CPM.

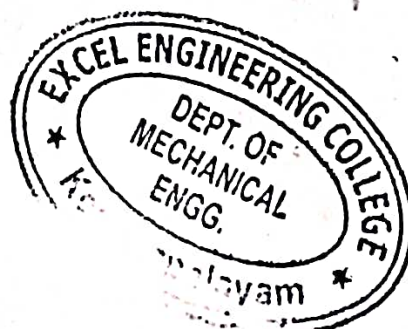
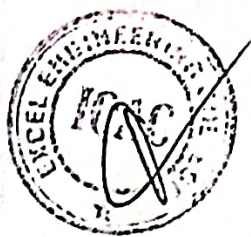

Syllabus for General Aptitude (GA)

(COMMON TO ALL PAPERS)

Verbal Ability: English grammar, sentence completion, verbal analogies, word groups, instructions, critical reasoning and verbal deduction.

Numerical Ability: Numerical computation, numerical estimation, numerical reasoning and data interpretation.

Sample Questions

Verbal Ability

Q.1. Choose the appropriate answer to complete the following sentence:

To those of us who had always thought him timid, his ----- came as a surprise.

(A) intrepidity (B) inevitability (C) inability (D) inertness

Ans. (A)

Q.2. Choose the appropriate answer to complete the following sentence:

Medicine is to illness as law is to _____

(A) discipline (B) anarchy (C) treason (D) etiquette

Ans. (B)

Q.3. Read the following paragraph :

"The ordinary form of mercury thermometer is used for temperature ranging from -40°F to 500°F . For measuring temperature below -40°F , thermometers filled with alcohol are used. These are, however, not satisfactory for use in high temperatures. When a mercury thermometer is used for temperature above 500°F , the space above the mercury is filled with some inert gas, usually nitrogen or carbon dioxide, placed in the thermometer under pressure. As the mercury rises, the gas pressure is increased, so that it is possible to use these thermometers for temperatures as high as 1000°F ."

With what, besides mercury, would a thermometer be filled if it was designed to be used for measuring temperature of about 500°F ?

(A) Pyrometer (B) Inert gas (C) Iron and brass (D) Gas

Ans. (B)

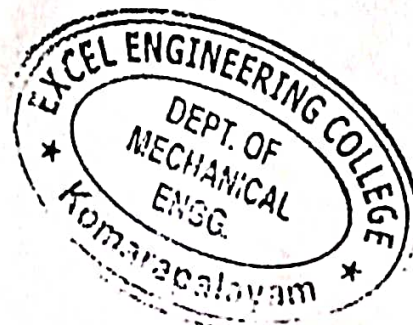

Q.4. The cost of manufacturing tractors in Korea is twenty percent less than the cost of manufacturing tractors in Germany. Even after transportation fees and import taxes are added, it is still cheaper to import tractors from Korea to Germany than to produce tractors in Germany.

Which of the following assertions is best supported by the above information?

- (A) Labour costs in Korea are twenty percent below those in Germany.
- (B) Importing tractors into Germany will eliminate twenty percent of the manufacturing jobs in Germany.
- (C) The costs of transporting a tractor from Korea to Germany is more than twenty percent of the cost of manufacturing the tractor in Korea.
- (D) The import taxes on a tractor imported from Korea to Germany is less than twenty percent of the cost of manufacturing the tractor in Germany.

Ans. (D)

Numerical Ability

Q.5. In a survey, $\frac{3}{16}$ of the people surveyed told that they preferred to use public transport while commuting daily to office. $\frac{5}{8}$ of the people surveyed told that they preferred to use their own vehicles. The remaining 75 respondents said that they had no clear preference. How many people preferred to use public transport?

- (A) 75 (B) 100 (C) 125 (D) 133

Ans. (A)

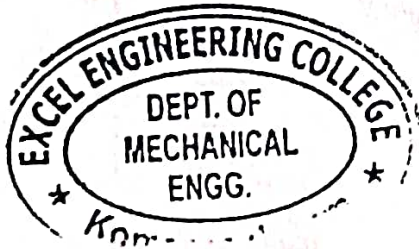

Q. 1 – Q. 25 carry one mark each.

Q.1 Consider the matrix

$$P = \begin{bmatrix} 1 & 1 & 0 \\ 0 & 1 & 1 \\ 0 & 0 & 1 \end{bmatrix}$$

The number of distinct eigenvalues of P is

- (A) 0 (B) 1 (C) 2 (D) 3

Q.2 A parabola $x = y^2$ with $0 \leq x \leq 1$ is shown in the figure. The volume of the solid of rotation obtained by rotating the shaded area by 360° around the x-axis is

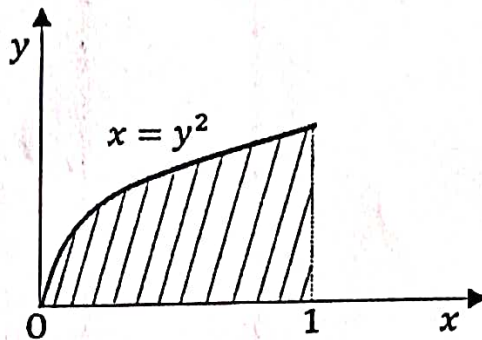

- (A) $\frac{\pi}{4}$ (B) $\frac{\pi}{2}$
 (C) π (D) 2π

Q.3 For the equation $\frac{dy}{dx} + 7x^2y = 0$, if $y(0) = 3/7$, then the value of $y(1)$ is

- (A) $\frac{7}{3}e^{-7/3}$ (B) $\frac{7}{3}e^{-3/7}$
 (C) $\frac{3}{7}e^{-7/3}$ (D) $\frac{3}{7}e^{-3/7}$

Q.4 The lengths of a large stock of titanium rods follow a normal distribution with a mean (μ) of 440 mm and a standard deviation (σ) of 1 mm. What is the percentage of rods whose lengths lie between 438 mm and 441 mm?

- (A) 81.85% (B) 68.4% (C) 99.75% (D) 86.64%

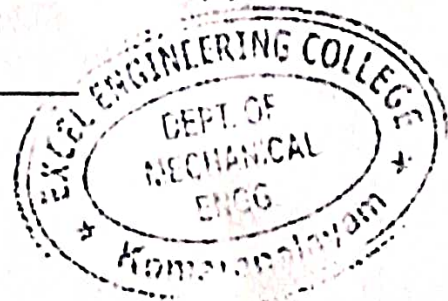

- Q.5 A flat-faced follower is driven using a circular eccentric cam rotating at a constant angular velocity ω . At time $t = 0$, the vertical position of the follower is $y(0) = 0$, and the system is in the configuration shown below.

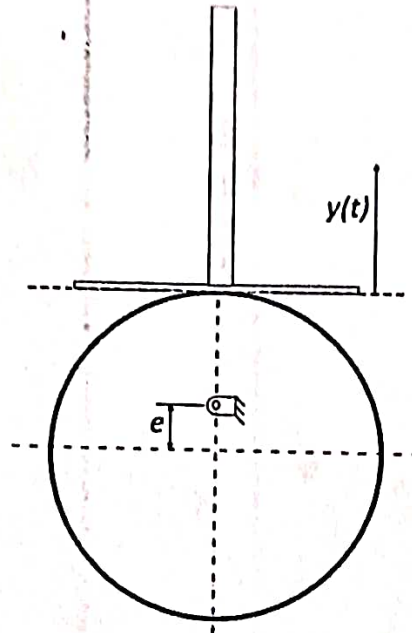

The vertical position of the follower face, $y(t)$ is given by

- (A) $e \sin \omega t$ (B) $e(1 + \cos 2\omega t)$ (C) $e(1 - \cos \omega t)$ (D) $e \sin 2\omega t$

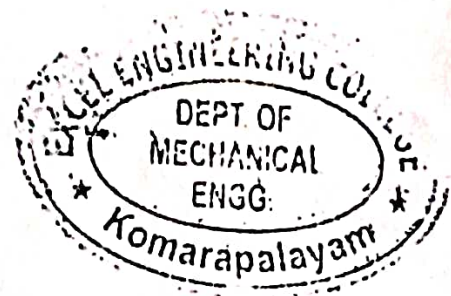

- Q.6 The natural frequencies corresponding to the spring-mass systems I and II are ω_I and ω_{II} , respectively. The ratio $\frac{\omega_I}{\omega_{II}}$ is

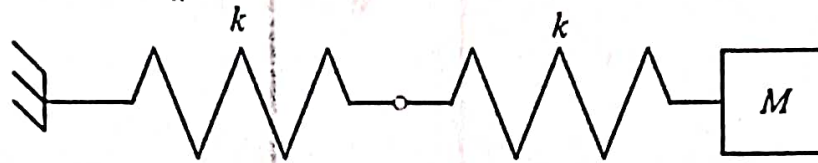

SYSTEM I

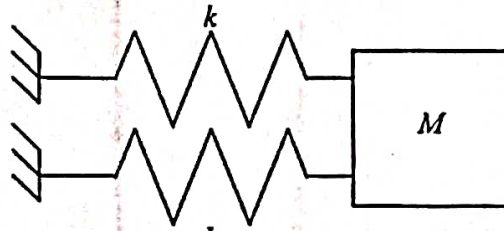

SYSTEM II

- (A) $\frac{1}{4}$ (B) $\frac{1}{2}$ (C) 2 (D) 4
- Q.7 A spur gear with 20° full depth teeth is transmitting 20 kW at 200 rad/s. The pitch circle diameter of the gear is 100 mm. The magnitude of the force applied on the gear in the radial direction is
- (A) 0.36 kN (B) 0.73 kN (C) 1.39 kN (D) 2.78 kN
- Q.8 During a non-flow thermodynamic process (1-2) executed by a perfect gas, the heat interaction is equal to the work interaction ($Q_{1-2} = W_{1-2}$) when the process is
- (A) Isentropic (B) Polytropic
(C) Isothermal (D) Adiabatic

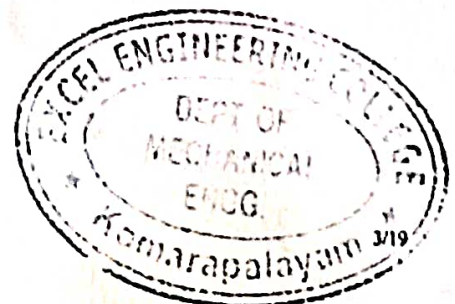

Q.9 For a hydrodynamically and thermally fully developed laminar flow through a circular pipe of constant cross-section, the Nusselt number at constant wall heat flux (Nu_q) and that at constant wall temperature (Nu_T) are related as

(A) $Nu_q > Nu_T$

(B) $Nu_q < Nu_T$

(C) $Nu_q = Nu_T$

(D) $Nu_q = (Nu_T)^2$

Q.10 As per common design practice, the three types of hydraulic turbines, in descending order of flow rate, are

(A) Kaplan, Francis, Pelton

(B) Pelton, Francis, Kaplan

(C) Francis, Kaplan, Pelton

(D) Pelton, Kaplan, Francis

Q.11 A slender rod of length L , diameter d ($L \gg d$) and thermal conductivity k_1 is joined with another rod of identical dimensions, but of thermal conductivity k_2 , to form a composite cylindrical rod of length $2L$. The heat transfer in radial direction and contact resistance are negligible. The effective thermal conductivity of the composite rod is

(A) $k_1 + k_2$

(B) $\sqrt{k_1 k_2}$

(C) $\frac{k_1 k_2}{k_1 + k_2}$

(D) $\frac{2k_1 k_2}{k_1 + k_2}$

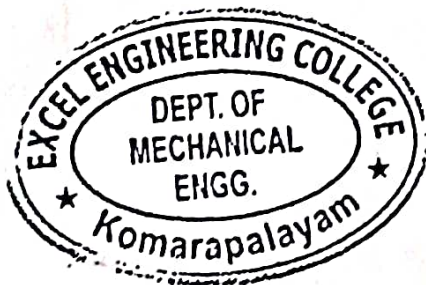



EXCEL ENGINEERING COLLEGE
(Autonomous)

Approved by AICTE, New Delhi & Affiliated to Anna University, Chennai

Accredited by NBA (AERO, CSE, ECE & MECH), NAAC with "A" and Recognised by UGC (2f & 12B)

DEPARTMENT OF MECHANICAL ENGINEERING
ATTENDANCE SHEET FOR GATE COACHING CLASS
(10.10.2022 TO 14.10.2022)

S.No	Student Name	October	October	October	October	October
		10-10-2022	11-10-2022	12-10-2022	13-10-2022	14-10-2022
1	AAKASH DEEP SHAH	A	P	P	P	P
2	AKASH P	P	P	P	P	P
3	AKHIL KUMAR	P	P	P	A	P
4	ALSON TONGBRAM	P	P	P	P	P
5	ANIL LAMSAL	P	P	P	P	P
6	ANKIT KUMAR	P	P	P	P	P
7	ARJUN P	P	P	P	P	P
8	ARUN R	P	P	A	P	P
9	ARUNKUMAR A	P	P	P	P	P
10	ARUN PANDIYAN T	P	A	P	P	P
11	ASHUTOSH KUMAR YADAV	P	P	P	P	P
12	BALAGANESH. R	P	P	P	P	P
13	BALAJI. M	P	P	P	P	A
14	BARATH M	P	P	P	P	P
15	BOOPATHI G	P	P	P	P	P
16	BOOPATHI RAJA M	P	A	P	P	P
17	DEVA K	P	P	P	A	P
18	DILDAS PB	P	P	P	P	P
19	DINAKAR S	P	P	P	P	P
20	DINAKARAN P	P	P	P	P	P
21	DINESH P	P	A	P	P	P
22	DINESH KUMAR.S	A	P	P	P	P
23	GAURAB KUMAR DUBEY	P	P	P	P	P
24	GAUTAM KUMAR	P	P	P	A	P
25	GOKUL KRISHNA	P	P	P	P	P
26	GOKUL S	P	P	P	P	P
27	GOPINATH V	P	P	P	P	P
28	GULSHAN KUMAR THAKUR	P	P	P	P	P
29	GUNASEKAR. S	P	P	A	P	P
30	HARIPRASATH S	P	P	P	P	P
31	MD FASHIULLAH	P	P	P	P	P
32	MD REHAN RAZA	P	P	P	P	P
33	MEIPRAKASH.C	P	P	P	P	P
34	MITHUN KUMAR	P	P	P	P	P
35	MOHAMED ANWARKHAN.S	P	P	P	P	P
36	MOHAN.R	P	P	P	P	A
37	MOHANA PRIYA.P	P	A	P	P	P
38	MUHAMMED AMEEN	P	P	P	P	P
39	MUTHUVEL.G	P	P	P	P	P
40	DINESH M	P	P	P	P	P

STAFF COORDINATOR

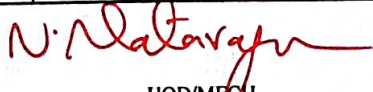
HOD/MECH

HEAD OF THE DEPARTMENT
MECHANICAL ENGINEERING,
EXCEL ENGINEERING COLLEGE,
KOMARPALATHI - 601 303.



EXCEL ENGINEERING COLLEGE
(Autonomous)

Approved by AICTE, New Delhi & Affiliated to Anna University, Chennai
Accredited by NBA (AERO, CSE, ECE & MECH), NAAC with "A*" and Recognised by UGC (2f & 12B)
KOMARAPALAYAM - 637303

DEPARTMENT OF MECHANICAL ENGINEERING

ACADEMIC YEAR: 2022 - 2023

**Indirect Assessment of Program Outcomes & Program Specific Outcomes
through Curricular and Extracurricular Activities**

Student Name : Gokul.S

Date: 10.10.2022

Batch : 2019-2023

Year/Semester: IV / VII - Sem

Type of Activity: Value added course / Industrial Visit / Implant Training / Guest Lecturer/
Seminar / Conference / Workshop / Design Contest/ Project Contest / Sports / Games / Social
Activities / Certificate Program / Diploma Course /hackathon/ Ideathon / GATE Exam/ or any. ✓

Organizing Institute: EXCEL ENGINEERING COLLEGE (AUTONOMOUS)

Place: KOMARAPALAYAM

Provide your level of attainment for the following questions by ✓ in the given,

[3/2/1 Indicates Level of Attainment; 3 – Very Much, 2 – Moderate, 1 – Some Extent]

1. Does this Activity/ Course improve your Technical Skill?

3 2 1

2. Does this Activity /Course improve your Problem Solving Skill?

3 2 1

3. Does this training / Course improve your practical Exposure?

3 2 1

4. Have you learnt any modern tools through this activity/ training?

Yes No if yes name of tool _____

5. Does this activity /training useful to improve your professional ethics?

3 2 1

6. Does this activity /training useful to apply for any modern research programs?

3 2 1

7. Have you got any ideas to improve our environmental & social needs?

3 2 1

8. Have you ever felt that your communication skill & leadership skill has been improved through this activity?

3 2 1

9. Does this Activity / training useful to improve learning attitude with zeal?

3 2 1

10. Does this Activity /training useful for you to work in multi-disciplinary team?

3 2 1

11. Does this Activity /training improve your mind to face any changes in your life?

3 2 1

Any other Comments:

Need more ~~post~~ practical knowledge required.

Gohel.S.
Signature



EXCEL ENGINEERING COLLEGE
(Autonomous)

Approved by AICTE, New Delhi & Affiliated to Anna University, Chennai
Accredited by NBA (AERO, CSE, ECE & MECH), NAAC with "A*" and Recognised by UGC (2f & 12B)
KOMARAPALAYAM - 637303

DEPARTMENT OF MECHANICAL ENGINEERING

ACADEMIC YEAR: 2022 - 2023

**Indirect Assessment of Program Outcomes & Program Specific Outcomes
through Curricular and Extracurricular Activities**

Student Name : ARUN. R

Date: 10.10.2022

Batch : 2019 - 2023

Year/Semester: IV / VII

Type of Activity: Value added course / Industrial Visit / Implant Training / Guest Lecturer/
Seminar / Conference / Workshop / Design Contest/ Project Contest / Sports / Games / Social
Activities / Certificate Program / Diploma Course /hackathon/ Ideathon / GATE Exam/ or any.

Organizing Institute: EXCEL ENGINEERING COLLEGE (AUTONOMOUS)

Place: KOMARAPALAYAM

Provide your level of attainment for the following questions by ✓ in the given,

[3/2/1 Indicates Level of Attainment; 3 – Very Much, 2 – Moderate, 1 – Some Extent]

1. Does this Activity/ Course improve your Technical Skill?

3 2 1

2. Does this Activity /Course improve your Problem Solving Skill?

3 2 1

3. Does this training / Course improve your practical Exposure?

3 2 1

4. Have you learnt any modern tools through this activity/ training?

Yes No if yes name of tool _____

5. Does this activity /training useful to improve your professional ethics?

3 2 1

6. Does this activity /training useful to apply for any modern research programs?

3 2 1

7. Have you got any ideas to improve our environmental & social needs?

3 2 1

8. Have you ever felt that your communication skill & leadership skill has been improved through this activity?

3 2 1

9. Does this Activity / training useful to improve learning attitude with zeal?

3 2 1

10. Does this Activity /training useful for you to work in multi-disciplinary team?

3 2 1

11. Does this Activity /training improve your mind to face any changes in your life?

3 2 1

Any other Comments:

NEED MORE PRACTICAL knowledge. required.

ARUN.A
Signature



EXCEL ENGINEERING COLLEGE
(Autonomous)

Approved by AICTE, New Delhi & Affiliated to Anna University, Chennai
Accredited by NBA (AERO, CSE, ECE & MECH), NAAC with "A*" and Recognised by UGC (2f & 12B)
KOMARAPALAYAM - 637303

DEPARTMENT OF MECHANICAL ENGINEERING

ACADEMIC YEAR: 2022 - 2023

**Indirect Assessment of Program Outcomes & Program Specific Outcomes
through Curricular and Extracurricular Activities**

Student Name : Anil Lamsal

Date: 10.10.2023

Batch : 2019-2023

Year/Semester: IV / VII

Type of Activity: Value added course / Industrial Visit / Implant Training / Guest Lecturer/
Seminar / Conference / Workshop / Design Contest/ Project Contest / Sports / Games / Social
Activities / Certificate Program / Diploma Course /hackathon/ Ideathon / GATE Exam/ or any.

Organizing Institute: Excel Engineering college (Autonomous)

Place: Komarapalayam

Provide your level of attainment for the following questions by ✓ in the given,

[3/2/1 Indicates Level of Attainment; 3 – Very Much, 2 – Moderate, 1 – Some Extent]

1. Does this Activity/ Course improve your Technical Skill?

3 2 1

2. Does this Activity /Course improve your Problem Solving Skill?

3 2 1

3. Does this training / Course improve your practical Exposure?

3 2 1

4. Have you learnt any modern tools through this activity/ training?

Yes No If yes name of tool _____

5. Does this activity /training useful to improve your professional ethics?

3 2 1

6. Does this activity /training useful to apply for any modern research programs?

3 2 1

7. Have you got any ideas to improve our environmental & social needs?

3 2 1

8. Have you ever felt that your communication skill & leadership skill has been improved through this activity?

3 2 1

9. Does this Activity / training useful to improve learning attitude with zeal?

3 2 1

10. Does this Activity /training useful for you to work in multi-disciplinary team?

3 2 1

11. Does this Activity /training improve your mind to face any changes in your life?

3 2 1

Any other Comments:

Need more Practical knowledge required

Signature





 **GPS Map Camera**

Namakkal, Tamil Nadu, India
CQWC+XHM Sports Ground, Tamil Nadu 638008, India



 **GPS Map Camera**

Namakkal, Tamil Nadu, India
CQWC+XHM Sports Ground, Tamil Nadu 638008, India



EXCEL ENGINEERING COLLEGE
(Autonomous)

Approved by AICTE, New Delhi & Affiliated to Anna University, Chennai
Accredited by NBA(AERO,CSE,ECE,MECH) , NAAC with "A" and Recognised by UGC (2f &12B)
KOMARAPALAYAM - 637303

DEPARTMENT OF MECHANICAL ENGINEERING

CIRCULAR

Date: 3.11.2022

It is informed that there will be a "GATE Coaching Class" starts from 06.11.2022 onwards at 4.30 PM to 6.00 PM in Paavaiammal Hall for our department students. So I request the faculty members to permit the students to attend without fail.

HOD/MECH

TO

1. Department Notice Board

Copy to,

1. Circulated to all faculty members
2. Principal
3. File

**HEAD OF THE DEPARTMENT
MECHANICAL ENGINEERING,
EXCEL ENGINEERING COLLEGE
KOMARAPALAYAM - 637 303.**

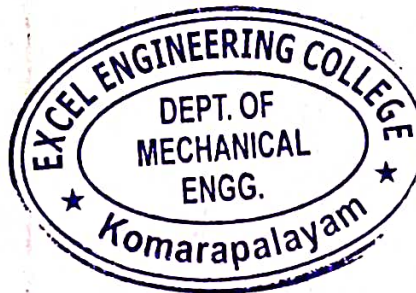



EXCEL ENGINEERING COLLEGE (Autonomous)

Approved by AICTE, New Delhi & Affiliated to Anna University, Chennai
Accredited by NBA (AERO, CSE, ECE & MECH), NAAC with "A" and Recognised by UGC (2f & 12B)
KOMARAPALAYAM - 637303

DEPARTMENT OF MECHANICAL ENGINEERING

GATE COACHING CLASS SCHEDULE (06.11.2022 to 10.11.2022)

S.NO	DAY	TOPIC	FACULTY NAME	DEPT	TIME	REMARKS
1	Monday (06.11.2022)	Heat Transfer	Dr.N.Tamilselvan	MECH	4.30 PM to 6.00 PM	
2	Tuesday (07.11.2022)	Thermodynamics	Dr.R.Vinoth	MECH	4.30 PM to 6.00 PM	
3	Wednesday (08.11.2022)	Fluid Mechanics	Dr.N.Venkadachalam	MECH	4.30 PM to 6.00 PM	
4	Thursday (09.11.2022)	Machine Design	Mr.V.Karthikeyan	MECH	4.30 PM to 6.00 PM	
5	Friday (10.11.2022)	Engineering Mechanics	Mr.T.M.Sakthimuruga	MECH	4.30 PM to 6.00 PM	

STAFF COORDINATOR

HOD/MECH

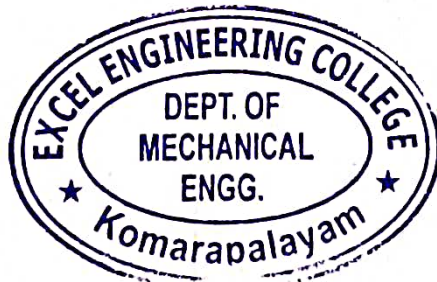

HEAD OF THE DEPARTMENT
MECHANICAL ENGINEERING,
EXCEL ENGINEERING COLLEGE
KOMARAPALAYAM - 637 303.

GATE
SYLLABUS

Section 1: Engineering Mathematics

Linear Algebra: Matrix algebra, systems of linear equations, eigenvalues and eigenvectors.

Calculus: Functions of single variable, limit, continuity and differentiability, mean value theorems, indeterminate forms; evaluation of definite and improper integrals; double and triple integrals; partial derivatives, total derivative, Taylor series (in one and two variables), maxima and minima, Fourier series; gradient, divergence and curl, vector identities, directional derivatives, line, surface and volume integrals, applications of Gauss, Stokes and Green's theorems.

Differential equations: First order equations (linear and nonlinear); higher order linear differential equations with constant coefficients; Euler-Cauchy equation; initial and boundary value problems; Laplace transforms; solutions of heat, wave and Laplace's equations.

Complex variables: Analytic functions; Cauchy-Riemann equations; Cauchy's integral theorem and integral formula; Taylor and Laurent series.

Probability and Statistics: Definitions of probability, sampling theorems, conditional probability; mean, median, mode and standard deviation; random variables, binomial, Poisson and normal distributions.

Numerical Methods: Numerical solutions of linear and non-linear algebraic equations; integration by trapezoidal and Simpson's rules; single and multi-step methods for differential equations.

Section 2: Applied Mechanics and Design

Engineering Mechanics: Free-body diagrams and equilibrium; trusses and frames; virtual work; kinematics and dynamics of particles and of rigid bodies in plane motion; impulse and momentum (linear and angular) and energy formulations, collisions.

Mechanics of Materials: Stress and strain, elastic constants, Poisson's ratio; Mohr's circle for plane stress and plane strain; thin cylinders; shear force and bending moment diagrams; bending and shear stresses; deflection of beams; torsion of circular shafts; Euler's theory of columns; energy methods; thermal stresses; strain gauges and rosettes; testing of materials with universal testing machine; testing of hardness and impact strength.

Theory of Machines: Displacement, velocity and acceleration analysis of plane mechanisms; dynamic analysis of linkages; cams; gears and gear trains; flywheels and governors; balancing of reciprocating and rotating masses; gyroscope.

Vibrations: Free and forced vibration of single degree of freedom systems, effect of damping; vibration isolation; resonance; critical speeds of shafts.

Machine Design: Design for static and dynamic loading; failure theories; fatigue strength and the S-N diagram; principles of the design of machine elements such as bolted, riveted and welded joints; shafts, gears, rolling and sliding contact bearings, brakes and clutches, springs.

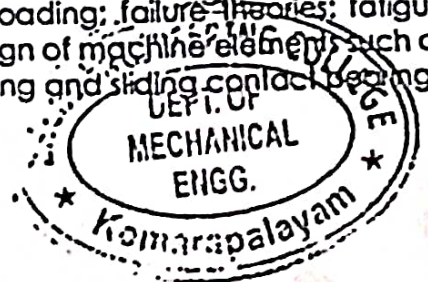

Section 3: Fluid Mechanics and Thermal Sciences

Fluid Mechanics: Fluid properties; fluid statics, manometry, buoyancy, forces on submerged bodies, stability of floating bodies; control-volume analysis of mass, momentum and energy; fluid acceleration; differential equations of continuity and momentum; Bernoulli's equation; dimensional analysis; viscous flow of incompressible fluids, boundary layer, elementary turbulent flow, flow through pipes, head losses in pipes, bends and fittings.

Heat-Transfer: Modes of heat transfer; one dimensional heat conduction, resistance concept and electrical analogy, heat transfer through fins; unsteady heat conduction, lumped parameter system, Heisler's charts; thermal boundary layer, dimensionless parameters in free and forced convective heat transfer, heat transfer correlations for flow over flat plates and through pipes, effect of turbulence; heat exchanger performance, LMTD and NTU methods; radiative heat transfer, Stefan-Boltzmann law, Wien's displacement law, black and grey surfaces, view factors, radiation network analysis.

Thermodynamics: Thermodynamic systems and processes; properties of pure substances, behaviour of ideal and real gases; zeroth and first laws of thermodynamics, calculation of work and heat in various processes; second law of thermodynamics; thermodynamic property charts and tables, availability and irreversibility; thermodynamic relations.

Applications: *Power Engineering:* Air and gas compressors; vapour and gas power cycles, concepts of regeneration and reheat, I.C. Engines: Air-standard Otto, Diesel and dual cycles. *Refrigeration and air-conditioning:* Vapour and gas refrigeration and heat pump cycles; properties of moist air, psychrometric chart, basic psychrometric processes. *Turbomachinery:* Impulse and reaction principles, velocity diagrams, Pelton-wheel, Francis and Kaplan turbines.

Section 4: Materials, Manufacturing and Industrial Engineering

Engineering Materials: Structure and properties of engineering materials, phase diagrams, heat treatment, stress-strain diagrams for engineering materials.

Casting, Forming and Joining Processes: Different types of castings, design of patterns, moulds and cores; solidification and cooling; riser and gating design. Plastic deformation and yield criteria; fundamentals of hot and cold working processes; load estimation for bulk (forging, rolling, extrusion, drawing) and sheet (shearing, deep drawing, bending) metal forming processes; principles of powder metallurgy. Principles of welding, brazing, soldering and adhesive bonding.

Machining and Machine Tool Operations: Mechanics of machining; basic machine tools; single and multi-point cutting tools, tool geometry and materials, tool life and wear, economics of machining; principles of non-traditional machining processes; principles of work holding, design of jigs and fixtures.

Metrology and Inspection: Limits, fits and tolerances; linear and angular measurements; comparators; gauge design; interferometry; form and finish measurement; alignment and testing methods; tolerance analysis in manufacturing and assembly.

Computer Integrated Manufacturing: Basic concepts of CAD/CAM and their integration tools.

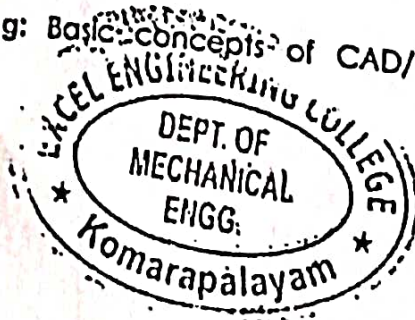

Production Planning and Control: Forecasting models, aggregate production planning, scheduling, materials requirement planning.

Inventory Control: Deterministic models; safety stock inventory control systems.

Operations Research: Linear programming, simplex method, transportation, assignment, network flow models, simple queuing models, PERT and CPM.

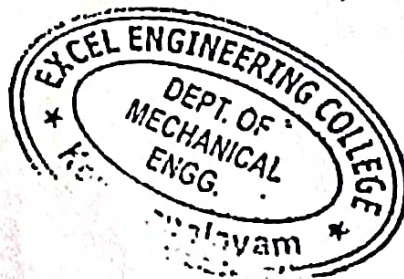

Syllabus for General Aptitude (GA)

(COMMON TO ALL PAPERS)

Verbal Ability: English grammar, sentence completion, verbal analogies, word groups, instructions, critical reasoning and verbal deduction.

Numerical Ability: Numerical computation, numerical estimation, numerical reasoning and data interpretation.

Sample Questions

Verbal Ability

Q.1. Choose the appropriate answer to complete the following sentence:

To those of us who had always thought him timid, his ----- came as a surprise.

- (A) intrepidity (B) inevitability (C) inability (D) inertness

Ans. (A)

Q.2. Choose the appropriate answer to complete the following sentence:

Medicine is to illness as law is to _____

- (A) discipline (B) anarchy (C) treason (D) etiquette

Ans. (B)

Q.3. Read the following paragraph :

"The ordinary form of mercury thermometer is used for temperature ranging from -40°F to 500°F . For measuring temperature below -40°F , thermometers filled with alcohol are used. These are, however, not satisfactory for use in high temperatures. When a mercury thermometer is used for temperature above 500°F , the space above the mercury is filled with some inert gas, usually nitrogen or carbon dioxide, placed in the thermometer under pressure. As the mercury rises, the gas pressure is increased, so that it is possible to use these thermometers for temperatures as high as 1000°F ."

With what, besides mercury, would a thermometer be filled if it was designed to be used for measuring temperature of about 500°F ?

- (A) Pyrometer (B) Inert gas (C) Iron and brass (D) Gas

Ans. (B)

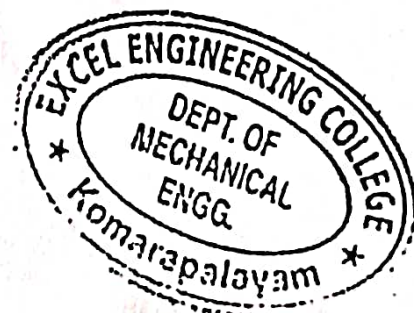

Q.4. The cost of manufacturing tractors in Korea is twenty percent less than the cost of manufacturing tractors in Germany. Even after transportation fees and import taxes are added, it is still cheaper to import tractors from Korea to Germany than to produce tractors in Germany.

Which of the following assertions is best supported by the above information?

- (A) Labour costs in Korea are twenty percent below those in Germany.
- (B) Importing tractors into Germany will eliminate twenty percent of the manufacturing jobs in Germany.
- (C) The costs of transporting a tractor from Korea to Germany is more than twenty percent of the cost of manufacturing the tractor in Korea.
- (D) The import taxes on a tractor imported from Korea to Germany is less than twenty percent of the cost of manufacturing the tractor in Germany.

Ans. (D)

Numerical Ability

Q.5. In a survey, $\frac{3}{16}$ of the people surveyed told that they preferred to use public transport while commuting daily to office. $\frac{5}{8}$ of the people surveyed told that they preferred to use their own vehicles. The remaining 75 respondents said that they had no clear preference. How many people preferred to use public transport?

- (A) 75 (B) 100 (C) 125 (D) 133

Ans. (A)

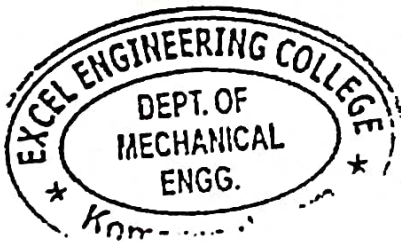

Q. 1 – Q. 25 carry one mark each.

Q.1 Consider the matrix

$$P = \begin{bmatrix} 1 & 1 & 0 \\ 0 & 1 & 1 \\ 0 & 0 & 1 \end{bmatrix}$$

The number of distinct eigenvalues of P is

- (A) 0 (B) 1 (C) 2 (D) 3

Q.2 A parabola $x = y^2$ with $0 \leq x \leq 1$ is shown in the figure. The volume of the solid of rotation obtained by rotating the shaded area by 360° around the x-axis is

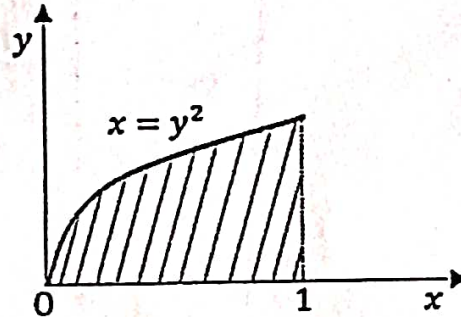

- (A) $\frac{\pi}{4}$ (B) $\frac{\pi}{2}$
 (C) π (D) 2π

Q.3 For the equation $\frac{dy}{dx} + 7x^2y = 0$, if $y(0) = 3/7$, then the value of $y(1)$ is

- (A) $\frac{7}{3}e^{-7/3}$ (B) $\frac{7}{3}e^{-3/7}$
 (C) $\frac{3}{7}e^{-7/3}$ (D) $\frac{3}{7}e^{-3/7}$

Q.4 The lengths of a large stock of titanium rods follow a normal distribution with a mean (μ) of 440 mm and a standard deviation (σ) of 1 mm. What is the percentage of rods whose lengths lie between 438 mm and 441 mm?

- (A) 81.85% (B) 68.4% (C) 99.75% (D) 86.64%

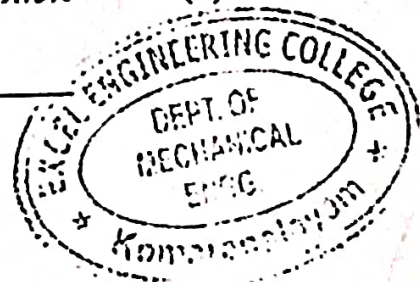

STATE NO.

Q.5 A flat-faced follower is driven using a circular eccentric cam rotating at a constant angular velocity ω . At time $t = 0$, the vertical position of the follower is $y(0) = 0$, and the system is in the configuration shown below.

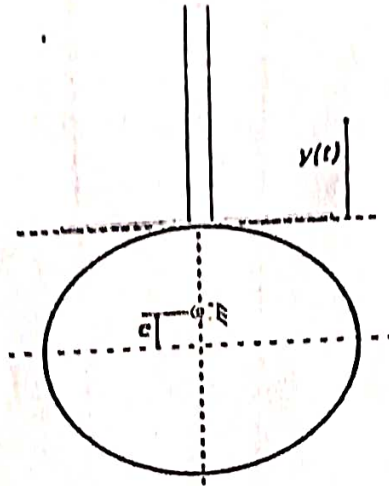

The vertical position of the follower face, $y(t)$ is given by

- (A) $e \sin \omega t$ (B) $a(1 + \cos 2\omega t)$ (C) $a(1 - \cos \omega t)$ (D) $e \sin 2\omega t$

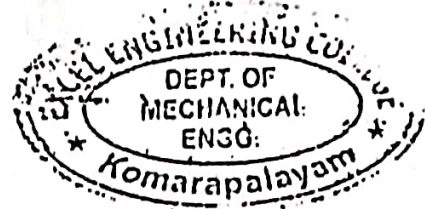

- Q.6 The natural frequencies corresponding to the spring-mass systems I and II are ω_I and ω_{II} , respectively. The ratio $\frac{\omega_I}{\omega_{II}}$ is

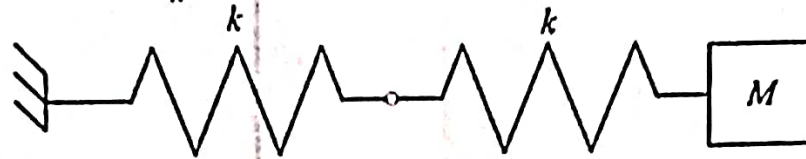

SYSTEM I

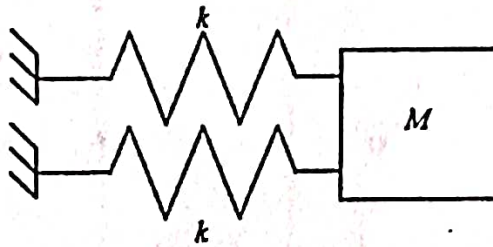

SYSTEM II

- (A) $\frac{1}{4}$ (B) $\frac{1}{2}$ (C) 2 (D) 4
- Q.7 A spur gear with 20° full depth teeth is transmitting 20 kW at 200 rad/s. The pitch circle diameter of the gear is 100 mm. The magnitude of the force applied on the gear in the radial direction is
- (A) 0.36 kN (B) 0.73 kN (C) 1.39 kN (D) 2.78 kN
- Q.8 During a non-flow thermodynamic process (1-2) executed by a perfect gas, the heat interaction is equal to the work interaction ($Q_{1-2} = W_{1-2}$) when the process is

- (A) Isentropic (B) Polytropic
(C) Isothermal (D) Adiabatic

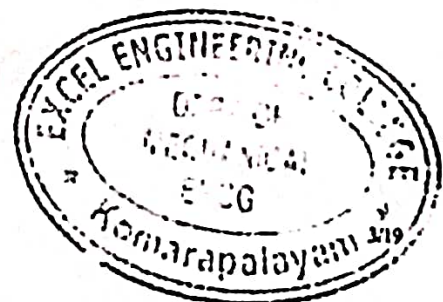

Q.9 For a hydrodynamically and thermally fully developed laminar flow through a circular pipe of constant cross-section, the Nusselt number at constant wall heat flux (Nu_q) and that at constant wall temperature (Nu_T) are related as

(A) $Nu_q > Nu_T$

(B) $Nu_q < Nu_T$

(C) $Nu_q = Nu_T$

(D) $Nu_q = (Nu_T)^2$

Q.10 As per common design practice, the three types of hydraulic turbines, in descending order of flow rate, are

(A) Kaplan, Francis, Pelton

(B) Pelton, Francis, Kaplan

(C) Francis, Kaplan, Pelton

(D) Pelton, Kaplan, Francis

Q.11 A slender rod of length L , diameter d ($L \gg d$) and thermal conductivity k_1 is joined with another rod of identical dimensions, but of thermal conductivity k_2 , to form a composite cylindrical rod of length $2L$. The heat transfer in radial direction and contact resistance are negligible. The effective thermal conductivity of the composite rod is

(A) $k_1 + k_2$

(B) $\sqrt{k_1 k_2}$

(C) $\frac{k_1 k_2}{k_1 + k_2}$

(D) $\frac{2k_1 k_2}{k_1 + k_2}$

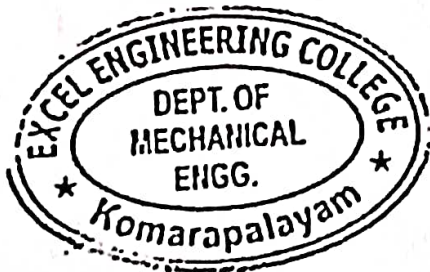



EXCEL ENGINEERING COLLEGE
(Autonomous)

Approved by AICTE, New Delhi & Affiliated to Anna University, Chennai

Accredited by NBA (AERO, CSE, ECE & MECH), NAAC with "A" and Recognised by UGC (2f & 12B)

DEPARTMENT OF MECHANICAL ENGINEERING
ATTENDANCE SHEET FOR GATE COACHING CLASS
(06.11.2022 TO 10.11.2022)

S.No	Student Name	November	November	November	November	November
		06-11-2022	07-11-2022	08-11-2022	09-11-2022	10-11-2022
1	AAKASH DEEP SHAH	A	P	P	P	P
2	AKASH P	P	P	P	P	P
3	AKHIL KUMAR	P	P	P	A	P
4	ALSON TONGBRAM	P	P	P	P	P
5	ANIL LAMSAL	P	P	P	P	P
6	ANKIT KUMAR	P	P	P	P	P
7	ARJUN P	P	P	P	P	P
8	ARUN R	P	P	A	P	P
9	ARUNKUMAR A	P	P	P	P	P
10	ARUN PANDIYAN T	P	A	P	P	P
11	ASHUTOSH KUMAR YADAV	P	P	P	P	P
12	BALAGANESH. R	P	P	P	P	P
13	BALAJI. M	P	P	P	P	A
14	BARATH M	P	P	P	P	P
15	BOOPATHI G	P	P	P	P	P
16	BOOPATHI RAJA M	P	A	P	P	P
17	DEVA K	P	P	P	A	P
18	DILDAS PB	P	P	P	P	P
19	DINAKAR S	P	P	P	P	P
20	DINAKARAN P	P	P	P	P	P
21	DINESH P	P	A	P	P	P
22	DINESH KUMAR.S	A	P	P	P	P
23	GAURAB KUMAR DUBEY	P	P	P	P	P
24	GAUTAM KUMAR	P	P	P	A	P
25	GOKUL KRISHNA	P	P	P	P	P
26	GOKUL S	P	P	P	P	P
27	GOPINATH V	P	P	P	P	P
28	GULSHAN KUMAR THAKUR	P	P	P	P	P
29	GUNASEKAR. S	P	P	A	P	P
30	HARIPRASATH S	P	P	P	P	P
31	MD FASHIULLAH	P	P	P	P	P
32	MD REHAN RAZA	P	P	P	P	P
33	MEIPRAKASH.C	P	P	P	P	P
34	MITHUN KUMAR	P	P	P	P	P
35	MOHAMED ANWARKHAN.S	P	P	P	P	P
36	MOHAN.R	P	P	P	P	A
37	MOHANA PRIYA.P	P	A	P	P	P
38	MUHAMMED AMEEN	P	P	P	P	P
39	MUTHUVEL.G	P	P	P	P	P
40	NAVEENKUMAR.A	P	P	P	P	P
41	PRANAV KOLLARA	P	P	P	P	P
42	PRANAV PRASANNAN	P	P	P	P	P
43	PRATHEESH	P	P	P	P	P
44	PRAVEEN.M	P	P	P	P	P
45	PREMLAL BASKI	P	P	P	P	P
46	RAHUL RAJESH.M	P	P	P	P	P
47	RAM KUMAR.S	P	P	P	P	P
48	RANJITH KUMAR.R	P	P	P	P	P
49	RITHIKKUMAR.B	P	P	P	P	P
50	ROSHAN KUMAR SHARMA	P	P	P	P	P
51	RUBENDRA.R	P	P	P	P	P
52	SAMIR AKHTAR	P	P	P	P	P
53	SANTHAKUMAR.K	P	P	P	P	P
54	SARABOJI.S	P	P	P	P	P
55	SASIKUMAR.S	P	P	P	P	P
56	SAURABH KUMAR DUBEY	P	P	P	P	P
57	SESHADRI.T	P	P	P	P	P
58	SHIBTAIN RAZA	P	P	P	P	P
59	SOURAV.MJ	P	P	P	P	P
60	DINESH M	P	P	P	P	P

STAFF COORDINATOR

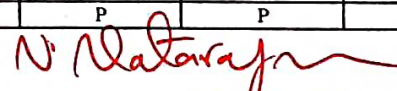
HOD/MECH
MECHANICAL ENGINEERING,
EXCEL ENGINEERING COLLEGE
KOMARAPALAYAM - 637 303.



EXCEL ENGINEERING COLLEGE
(Autonomous)

Approved by AICTE, New Delhi & Affiliated to Anna University, Chennai
Accredited by NBA (AERO, CSE, ECE & MECH), NAAC with "A*" and Recognised by UGC (2f & 12B)
KOMARAPALAYAM - 637303

DEPARTMENT OF MECHANICAL ENGINEERING

ACADEMIC YEAR: 2022 - 2023

**Indirect Assessment of Program Outcomes & Program Specific Outcomes
through Curricular and Extracurricular Activities**

Student Name : *Balaji .M.*

Date: *6-11-2022*

Batch : *2019-2023*

Year/Semester: *10/ 7th*

Type of Activity: Value added course / Industrial Visit / Implant Training / Guest Lecturer/
Seminar / Conference / Workshop / Design Contest/ Project Contest / Sports / Games / Social
Activities / Certificate Program / Diploma Course /hackathon/ Ideathon / GATE Exam/ or any. ✓

Organizing Institute: *Excel Engineering College (Autonomous)*

Place: *Komarapalayam.*

Provide your level of attainment for the following questions by ✓ in the given,

[3/2/1 Indicates Level of Attainment; 3 – Very Much, 2 – Moderate, 1 – Some Extent]

1. Does this Activity/ Course improve your Technical Skill?

3 2 1

2. Does this Activity /Course improve your Problem Solving Skill?

3 2 1

3. Does this training / Course improve your practical Exposure?

3 2 1

4. Have you learnt any modern tools through this activity/ training?

Yes No if yes name of tool _____

5. Does this activity /training useful to improve your professional ethics?

3 2 1

6. Does this activity /training useful to apply for any modern research programs?

3 2 1

7. Have you got any ideas to improve our environmental & social needs?

3 2 1

8. Have you ever felt that your communication skill & leadership skill has been improved through this activity?

3 2 1

9. Does this Activity / training useful to improve learning attitude with zeal?

3 2 1

10. Does this Activity /training useful for you to work in multi-disciplinary team?

3 2 1

11. Does this Activity /training improve your mind to face any changes in your life?

3 2 1

Any other Comments:

need more practical knowledge required.

Balsaj.m
Signature



EXCEL ENGINEERING COLLEGE
(Autonomous)

Approved by AICTE, New Delhi & Affiliated to Anna University, Chennai
Accredited by NBA (AERO, CSE, ECE & MECH), NAAC with "A+" and Recognised by UGC (2f & 12B)
KOMARAPALAYAM - 637303

DEPARTMENT OF MECHANICAL ENGINEERING

ACADEMIC YEAR: 2022 - 2023

**Indirect Assessment of Program Outcomes & Program Specific Outcomes
through Curricular and Extracurricular Activities**

Student Name : Akash P

Date: 6-11-2022

Batch : 2019-2023

Year/Semester: IV/7th

Type of Activity: Value added course / Industrial Visit / Implant Training / Guest Lecturer/
Seminar / Conference / Workshop / Design Contest/ Project Contest / Sports / Games / Social
Activities / Certificate Program / Diploma Course /hackathon/ Ideathon / GATE Exam/ or any.

Organizing Institute: Excel Engineering College (Autonomous)

Place: Komarapalayam

Provide your level of attainment for the following questions by ✓ in the given,

[3/2/1 Indicates Level of Attainment; 3 – Very Much, 2 – Moderate, 1 – Some Extent]

1. Does this Activity/ Course improve your Technical Skill?

3 2 1

2. Does this Activity /Course improve your Problem Solving Skill?

3 2 1

3. Does this training / Course improve your practical Exposure?

3 2 1

4. Have you learnt any modern tools through this activity/ training?

Yes No if yes name of tool _____

5. Does this activity /training useful to improve your professional ethics?

3 2 1

6. Does this activity /training useful to apply for any modern research programs?

3 2 1

7. Have you got any ideas to improve our environmental & social needs?

3 2 1

8. Have you ever felt that your communication skill & leadership skill has been improved through this activity?

3 2 1

9. Does this Activity / training useful to improve learning attitude with zeal?

3 2 1

10. Does this Activity /training useful for you to work in multi-disciplinary team?

3 2 1

11. Does this Activity /training improve your mind to face any changes in your life?

3 2 1

Any other Comments:

Need more practical knowledge required

Signature



EXCEL ENGINEERING COLLEGE
(Autonomous)

Approved by AICTE, New Delhi & Affiliated to Anna University, Chennai
Accredited by NBA (AERO, CSE, ECE & MECH), NAAC with "A" and Recognised by UGC (2f & 12B)
KOMARAPALAYAM - 637303

DEPARTMENT OF MECHANICAL ENGINEERING

ACADEMIC YEAR: 2022 - 2023

**Indirect Assessment of Program Outcomes & Program Specific Outcomes
through Curricular and Extracurricular Activities**

Student Name : MOHAN . R

Date: 6 - 11 - 2022

Batch : 2019-2023

Year/Semester: IV / 7th

Type of Activity: Value added course / Industrial Visit / Implant Training / Guest Lecturer/
Seminar / Conference / Workshop / Design Contest/ Project Contest / Sports / Games / Social
Activities / Certificate Program / Diploma Course /hackathon/ Ideathon / GATE Exam/ or any.

Organizing Institute: EXCEL ENGINEERING COLLEGE
(Autonomous)

Place: Komarapalayam

Provide your level of attainment for the following questions by ✓ in the given,

[3/2/1 Indicates Level of Attainment; 3 - Very Much, 2 - Moderate, 1 - Some Extent]

1. Does this Activity/ Course improve your Technical Skill?

3 2 1

2. Does this Activity /Course improve your Problem Solving Skill?

3 2 1

3. Does this training / Course improve your practical Exposure?

3 2 1

4. Have you learnt any modern tools through this activity/ training?

Yes No if yes name of tool _____

5. Does this activity /training useful to improve your professional ethics?

3 2 1

6. Does this activity /training useful to apply for any modern research programs?

3 2 1

7. Have you got any ideas to improve our environmental & social needs?

3 2 1

8. Have you ever felt that your communication skill & leadership skill has been improved through this activity?

3 2 1

9. Does this Activity / training useful to improve learning attitude with zeal?

3 2 1

10. Does this Activity /training useful for you to work in multi-disciplinary team?

3 2 1

11. Does this Activity /training improve your mind to face any changes in your life?

3 2 1

Any other Comments:

Need more practical knowledge required.

R. Mahan
Signature



 **GPS Map Camera**

Namakkal, Tamil Nadu, India
CQWC+XHM Sports Ground, Tamil Nadu 638008, India



 **GPS Map Camera**

Namakkal, Tamil Nadu, India
CQWC+XHM Sports Ground, Tamil Nadu 638008, India